

Crestron **MMK-CBF-T**
Mud Ring Mount Kit for Cameo™2

Installation Guide



Contents

Mud Ring Mount Kit for Cameo™ 2: MMK-CBF-T	1
Description	1
Setup.....	2
Supplied Hardware	2
Installation	3
Resources	6
Industry Compliance.....	6
Reference Documents.....	6
Further Inquiries	6
Future Updates.....	6
Return and Warranty Policies	8
Merchandise Returns / Repair Service	8
CRESTRON Limited Warranty	8

All brand names, product names and trademarks are the property of their respective owners.
©2007 Crestron Electronics, Inc.

Mud Ring Mount Kit for Cameo™ 2: MMK-CBF-T

Description

This Mud Ring Mount Kit for Cameo 2 is the preferred mounting option for the Crestron® Cameo 2 C2N-CBF-T flush-mount model keypads when cutouts made in the mounting surface are too large. This kit provides support for additional plastering that can be applied to hide large irregularities in the cutout.

NOTE: This mounting option is intended for Cameo 2 flush-mount keypads only. Do not attempt to use the MMK-CBF-T with Cameo 2 standard-mount model keypads or any of the original Cameo keypads.

Setup

Supplied Hardware

The hardware supplied with the MMK-CBF-T is listed in the following table.

Supplied Hardware for the MMK-CBF-T

DESCRIPTION	PART NUMBER	QUANTITY
Metal Mud Ring Plate	2019462	1
Template	4505492	1

Overall Dimensions – MMK-CBF-T

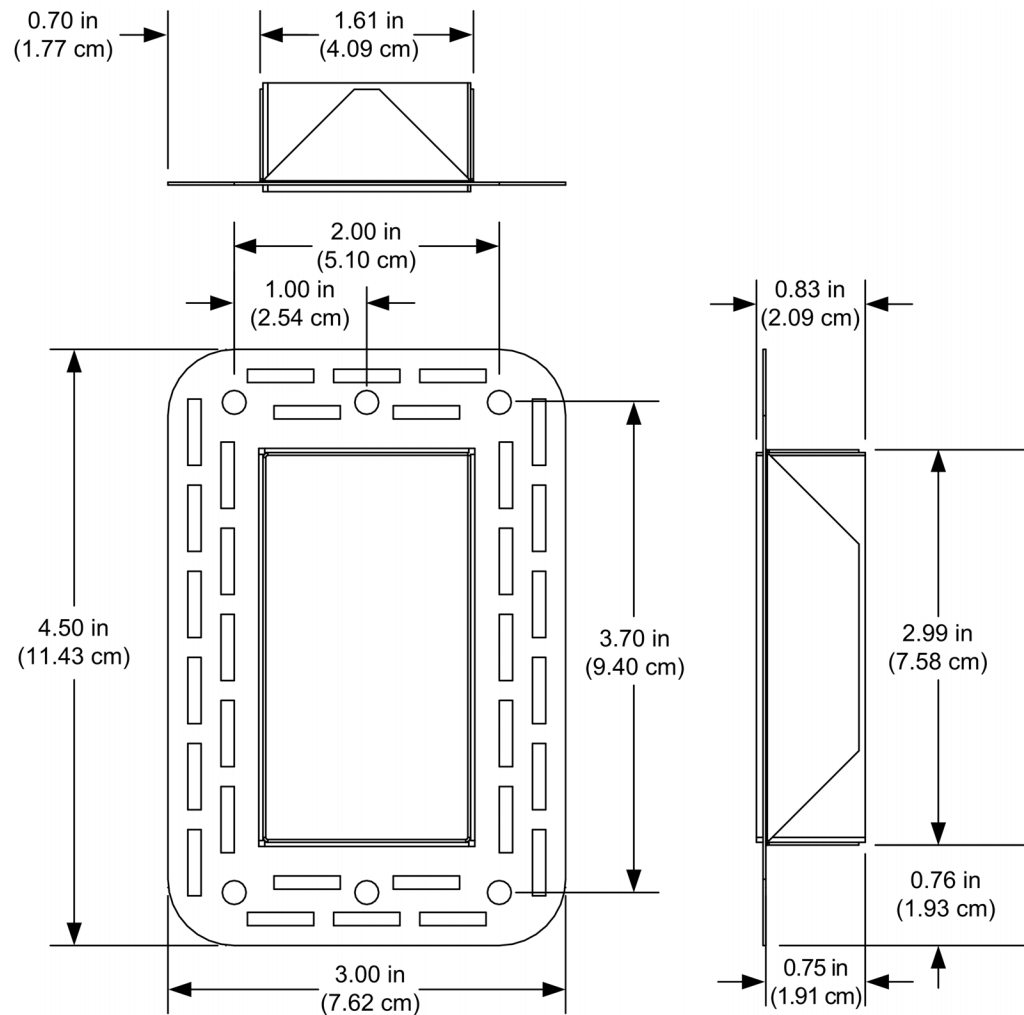

Installation

It is assumed that the keypad has been assembled and that the template supplied with the keypad has been used to prepare a hole in the wall according to the procedures in the latest version of the C2N-CBF-T Operations and Installation Guide (Doc. 6603), available from the Crestron website (<http://www.crestron.com/manuals>). It is also assumed that the drywall in place has an irregular rectangular cutout that requires the use of the mud ring mount kit.

The only tools or materials required and not supplied are:

- Level
- Hand saw suitable for cutting a hole in the drywall
- Four standard drywall screws
- #2 Phillips screwdriver
- Tools/material to apply drywall joint compound

The following figure (not to scale) illustrates the supplied template used to prepare the hole in the wall or other mounting surface for the metal mud ring plate (mud ring).

NOTE: Use only the original template, not a photocopy, to prepare the hole. Photocopies usually alter the size of the image slightly, which would make the hole the wrong size.

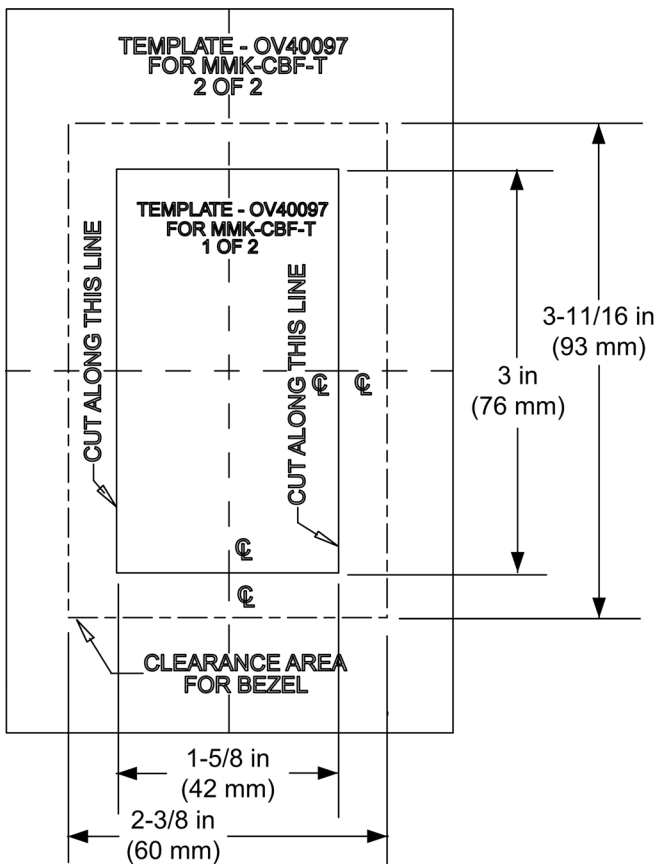

Use the level to position the supplied template over the irregular rectangular cutout.

1. Secure the template in position and use a drywall handsaw to straighten and enlarge the hole as necessary to accommodate the mud ring.
2. Insert the mud ring into the enlarged cutout, as shown in the following illustration. (The C2N-CBF-T keypad is shown for reference.)

Insert and Secure Mud Ring

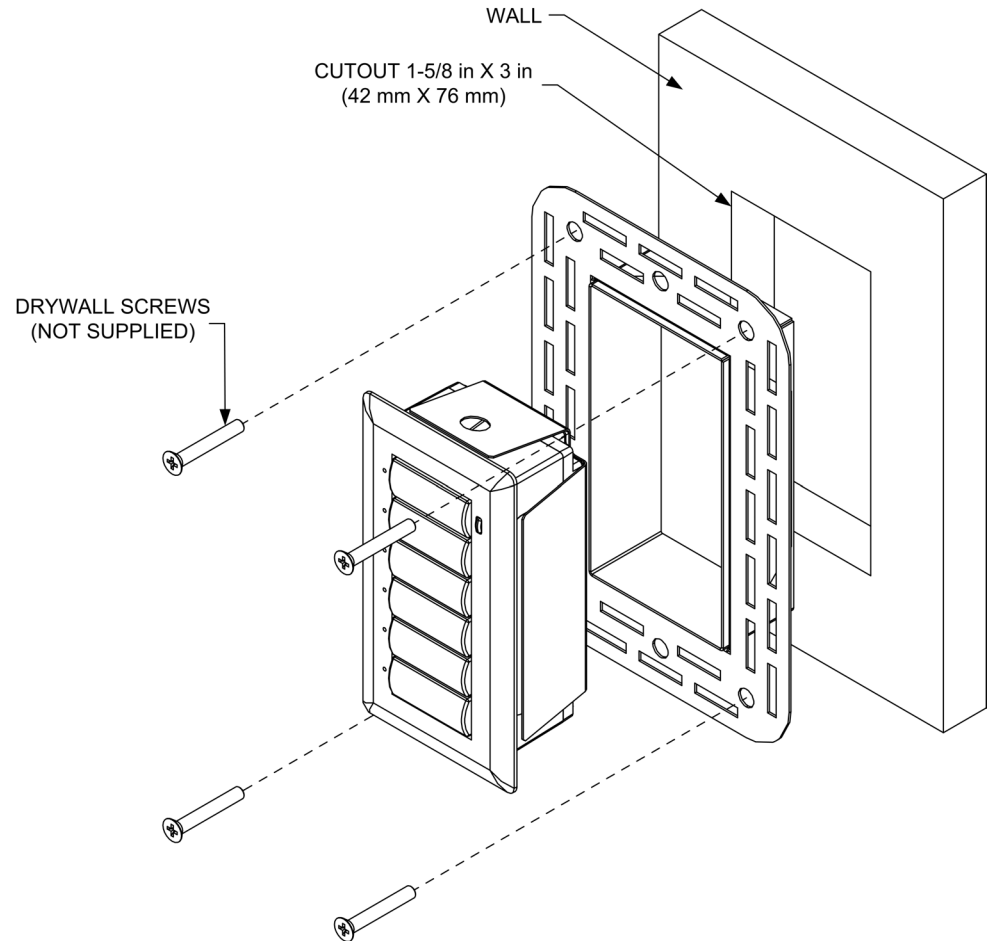

3. When the mud ring is in position, loosely secure with four #6 drywall screws (not supplied). The length of the screws should not exceed the wall thickness by more than $\frac{1}{2}$ inch.
4. Verify that the mud ring is level.

NOTE: Do not over tighten the screws. Doing so may over-dimple or rip the mud ring.

5. Use a screwdriver to tighten the drywall screws by hand so that they slightly dimple into the holes in the mud ring.
6. Apply drywall compound as needed to finish the cutout.
7. When dry, refer to the latest version of the Cameo 2 Keypads Operation & Installation Guide (Doc. 6603) to complete the installation.

Resources

Industry Compliance

As of the date of manufacture, the MMK-CBF-T has been tested and found to comply with specifications for CE marking.



Reference Documents

The latest version of all documents mentioned within the guide can be obtained from the Crestron website (www.crestron.com/manuals). This link will provide a list of product manuals arranged in alphabetical order by model number.

List of Related Reference Documents

DOCUMENT TITLE
C2N-CBD-TS/C2N-CBF-T Cameo 2 Keypads

Further Inquiries

If you cannot locate specific information or have questions after reviewing this guide, please take advantage of Crestron's award winning customer service team by calling the Crestron corporate headquarters at 1-888-CRESTRON [1-888-273-7876]. For assistance in your local time zone, refer to the Crestron website (www.crestron.com/offices) for a listing of Crestron worldwide offices.

You can also log onto the online help section of the Crestron website (www.crestron.com/onlinehelp) to ask questions about Crestron products. First-time users will need to establish a user account to fully benefit from all available features.

Future Updates

As Crestron improves functions, adds new features and extends the capabilities of the MMK-CBF-T, additional information may be made available as manual updates. These updates are solely electronic and serve

as intermediary supplements prior to the release of a complete technical documentation revision.

Check the Crestron website periodically for manual update availability and its relevance. Updates are identified as an “Addendum” in the Download column.

Return and Warranty Policies

Merchandise Returns / Repair Service

1. No merchandise may be returned for credit, exchange or service without prior authorization from CRESTRON. To obtain warranty service for CRESTRON products, contact an authorized CRESTRON dealer. Only authorized CRESTRON dealers may contact the factory and request an RMA (Return Merchandise Authorization) number. Enclose a note specifying the nature of the problem, name and phone number of contact person, RMA number and return address.
2. Products may be returned for credit, exchange or service with a CRESTRON Return Merchandise Authorization (RMA) number. Authorized returns must be shipped freight prepaid to CRESTRON, 6 Volvo Drive, Rockleigh, N.J. or its authorized subsidiaries, with RMA number clearly marked on the outside of all cartons. Shipments arriving freight collect or without an RMA number shall be subject to refusal. CRESTRON reserves the right in its sole and absolute discretion to charge a 15% restocking fee plus shipping costs on any products returned with an RMA.
3. Return freight charges following repair of items under warranty shall be paid by CRESTRON, shipping by standard ground carrier. In the event repairs are found to be non-warranty, return freight costs shall be paid by the purchaser.

CRESTRON Limited Warranty

CRESTRON ELECTRONICS, Inc. warrants its products to be free from manufacturing defects in materials and workmanship under normal use for a period of three (3) years from the date of purchase from CRESTRON, with the following exceptions: disk drives and any other moving or rotating mechanical parts, pan/tilt heads and power supplies are covered for a period of one (1) year; touchscreen display and overlay components are covered for 90 days; batteries and incandescent lamps are not covered.

This warranty extends to products purchased directly from CRESTRON or an authorized CRESTRON dealer. Purchasers should inquire of the dealer regarding the nature and extent of the dealer's warranty, if any.

CRESTRON shall not be liable to honor the terms of this warranty if the product has been used in any application other than that for which it was intended or if it has been subjected to misuse, accidental damage, modification or improper installation procedures. Furthermore, this warranty does not cover any product that has had the serial number altered, defaced or removed.

This warranty shall be the sole and exclusive remedy to the original purchaser. In no event shall CRESTRON be liable for incidental or consequential damages of any kind (property or economic damages inclusive) arising from the sale or use of this equipment. CRESTRON is not liable for any claim made by a third party or made by the purchaser for a third party.

CRESTRON shall, at its option, repair or replace any product found defective, without charge for parts or labor. Repaired or replaced equipment and parts supplied under this warranty shall be covered only by the unexpired portion of the warranty.

Except as expressly set forth in this warranty, CRESTRON makes no other warranties, expressed or implied, nor authorizes any other party to offer any warranty, including any implied warranties of merchantability or fitness for a particular purpose. Any implied warranties that may be imposed by law are limited to the terms of this limited warranty. This warranty statement supersedes all previous warranties.

Trademark Information

All brand names, product names and trademarks are the sole property of their respective owners. Windows is a registered trademark of Microsoft Corporation. Windows95/98/Me/XP/Vista and WindowsNT/2000 are trademarks of Microsoft Corporation.

This page is intentionally left blank.



Crestron Electronics, Inc.
15 Volvo Drive Rockleigh, NJ 07647
Tel: 888.CRESTRON
Fax: 201.767.7576
www.crestron.com

Installation Guide – DOC. 6637A
(2019524)

12.07

Specifications subject to
change without notice.